

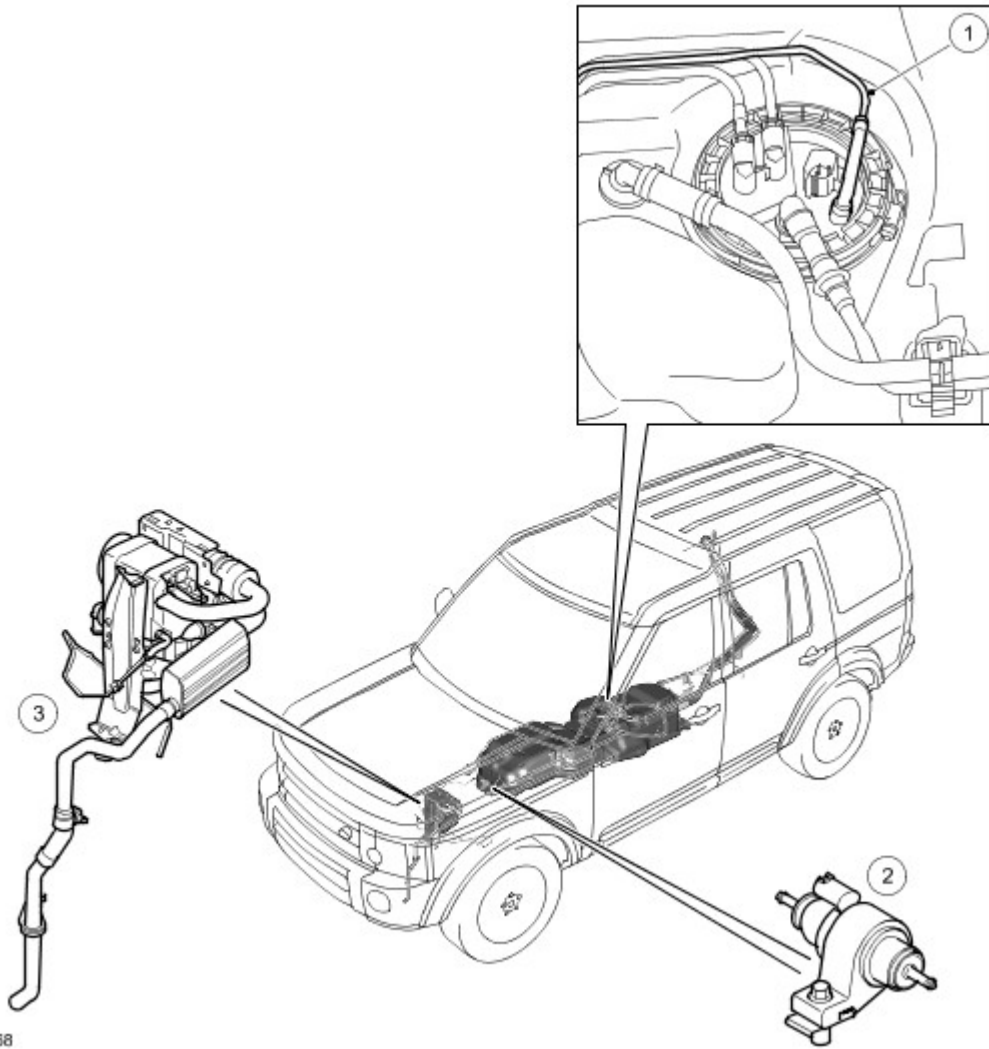

Auxiliary Heater

COMPONENT LOCATIONS



E43568

Item	Part Number	Description
1	-	Fuel line connection with fuel tank
2	-	Auxiliary fuel pump
3	-	Fuel fired booster heater

GENERAL

Auxiliary heating is provided by a Fuel Fired Booster Heater (FFBH), which boosts the temperature of the coolant supplied to the heater from the engine. Fuel for the FFBH is taken from the vehicle fuel tank, through a fuel line attached to the fuel pump module. An auxiliary fuel pump supplies the fuel at low pressure to the FFBH. In the FFBH, the fuel is burned and the resultant heat output is used to heat the engine coolant.

Operation of the FFBH is enabled and disabled by the Automatic Temperature Control Module (ATCM).

FFBH

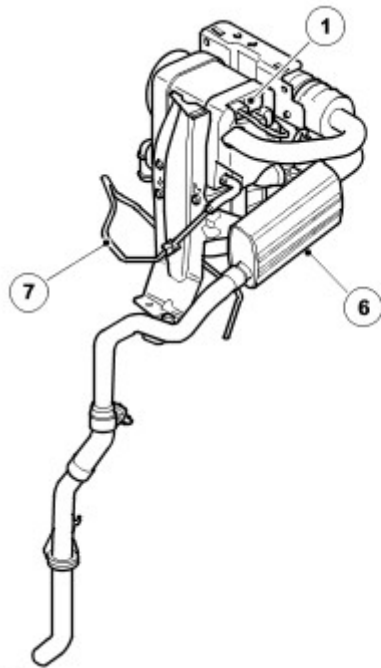

E43570

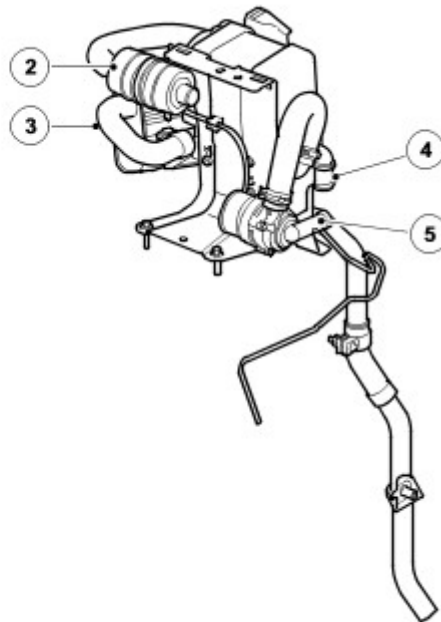

Item	Part Number	Description
1	-	Electrical connectors
2	-	Air inlet silencer
3	-	Exhaust pipe
4	-	Coolant outlet connection
5	-	Coolant inlet connection
6	-	Silencer
7	-	Fuel supply line

The FFBH is installed in the front left corner of the engine compartment. It is connected in series with the coolant supply to the heater assembly. Two electrical connectors on the FFBH connect it to the vehicle wiring.

The FFBH unit consists of:

- A circulation pump.
- A combustion air fan.
- A burner housing.
- A heat exchanger.
- An air inlet hose and filter.
- An exhaust pipe.
- A control module.

Circulation Pump

The circulation pump is installed at the coolant inlet to the FFBH to assist the coolant flow through the FFBH and the vehicle heater core. The circulation pump runs continuously while the FFBH is in standby or active operating modes. While the FFBH is inactive, coolant flow is reliant on the engine coolant pump. Operation of the circulation pump is controlled by a power feed direct from the control module.

Combustion Air Fan

The combustion air fan regulates the flow of air into the FFBH to support combustion of the fuel supplied by the auxiliary fuel pump and to purge and cool the FFBH.

Burner Housing

The burner housing contains the burner insert and also incorporates connections for the exhaust pipe, the coolant inlet from the circulation pump and the coolant outlet to the vehicle heater core.

The burner insert incorporates the fuel combustion chamber, an evaporator and a glow pin and flame sensor. Fuel from the auxiliary fuel pump is supplied to a venturi, where it evaporates and enters the combustion chamber to mix with air from the combustion air fan. The glow pin and flame sensor provides the ignition source of the fuel:air mixture and, once combustion is established, monitors the flame.

Heat Exchanger

The heat exchanger transfers heat generated by combustion to the coolant. Two sensors are installed in the heat exchanger casing to provide the control module with inputs of coolant temperature. The control module uses the temperature inputs to control system operation.

Air Inlet Hose and Silencer

A canister type silencer is included in the air inlet supply line. The silencer reduces the noise caused by induction roar.

Exhaust Pipe and Muffler

The exhaust pipe and muffler directs exhaust combustion gases to atmosphere below the front left corner of the engine. Exhaust vapor may be visible when the FFBH is running, depending on atmospheric conditions.

Control Module

The control module controls and monitors operation of the FFBH system. An internal flow of air from the combustion air fan ventilates the control module to prevent it overheating.

The control module communicates with other systems on the vehicle over the medium speed Controller Area Network (CAN) bus.

FFBH Control Module Harness Connector C0925

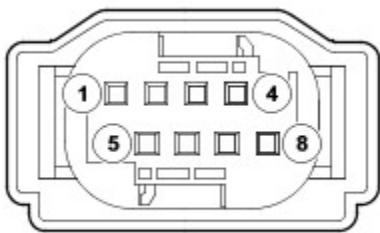

E50045

FFBH Control Module Harness Connector C0925 Pin Details

Pin No.	Description	Input/Output
1	Not used	-
2 and 3	Not used	-
4	Medium speed CAN bus low	Input/Output
5	Auxiliary fuel pump power feed	Output
6	Not used	-

7	Medium speed CAN bus high	Input/Output
8	Not used	-

FFBH Control Module Harness Connector C0926

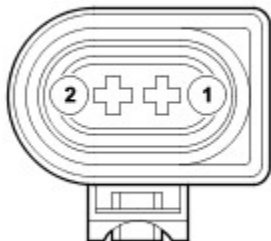

E50046

FFBH Control Module Harness Connector C0926 Pin Details

Pin No.	Description	Input/Output
1	Permanent battery power supply	Input
2	Ground	Output

AUXILIARY FUEL PUMP

The auxiliary fuel pump regulates the fuel supply to the FFBH. The pump is installed in a rubber mounting attached to the chassis, below the RH front seat. The pump is a self priming, solenoid operated plunger pump, controlled by a Pulse Width Modulated (PWM) signal from the control module in the FFBH. When the pump is de-energized, it provides a positive shut-off of the fuel supply.

Sectioned View of Auxiliary Fuel Pump

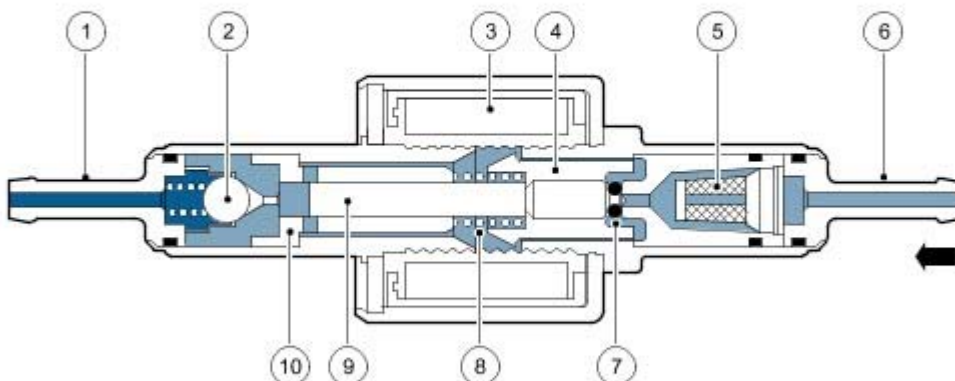

E43569

Item	Part Number	Description
1	-	Fuel line connector
2	-	Non return valve
3	-	Solenoid coil
4	-	Plunger
5	-	Filter insert
6	-	Fuel line connector
7	-	O-ring seal
8	-	Spring
9	-	Piston
10	-	Bush

The solenoid coil of the auxiliary fuel pump is installed around a housing which contains a plunger and piston. The piston locates in a bush, and a spring is installed on the piston between the bush and the plunger. A filter insert and a fuel line connector are installed in the inlet end of the housing. A non return valve and a fuel line connector are installed in the fuel outlet end of the housing.

While the solenoid coil is de-energized, the spring holds the piston and plunger in the closed position at the inlet end of the housing. An O-ring seal on the plunger provides a fuel tight seal between the plunger and the filter insert, preventing any flow through the pump. When the solenoid coil is energized, the piston and plunger move towards the outlet end of the housing, until the plunger contacts the bush; fuel is then drawn in through the inlet connection and filter. The initial movement of the piston also closes transverse drillings in the bush and isolates the pumping chamber at the outlet end of the housing. Subsequent movement of the piston then forces fuel from the pumping chamber through the non return valve and into the line to the FFBH. When the solenoid de-energizes, the spring moves the piston and plunger back towards the closed position. As the piston and plunger move towards the closed position, fuel flows past the plunger and through the annular gaps and transverse holes in the bush to replenish the pumping chamber.

SYSTEM OPERATION

The FFBH system supplements vehicle heater performance while the engine is running, and is transparent to the driver.

Operation of the FFBH is controlled by a medium speed CAN bus message from the ATCM, which contains the operating mode required of the FFBH. When the message contains the heating mode, the control module in the FFBH starts the FFBH.

While the medium speed CAN bus is active, the control module sends these messages:

The control module will not start the FFBH, or will discontinue operation, if any of the following occur:

- The control module is in the lockout mode (see **Diagnostics** at the end of this section).
- A crash message is received from the restraints control module. For additional information, refer to [Air Bag and Safety Belt Pretensioner Supplemental Restraint System \(SRS\)](#) (501-20B Supplemental Restraint System)
- A low fuel level message is received from the instrument cluster. For additional information, refer to [Instrument Cluster](#) (413-01 Instrument Cluster)
- The battery voltage is too low. When starting the FFBH, battery voltage must be 10.25 - 15.5 volts. When the FFBH is running, operation will be discontinued if battery voltage decreases to less than 10.25 volts.

The FFBH is controlled at one of two heat output levels, 2.5 kW at part load combustion and 5 kW at full load combustion.

Start Sequence: At the beginning of a start sequence, the control module energizes the glow pin function of the glow pin and flame sensor, to pre heat the combustion chamber, starts the combustion air fan at slow speed and energizes the coolant circulation pump. After approximately 30 seconds, the control module energizes the auxiliary fuel pump at the starting sequence speed. The fuel delivered by the auxiliary fuel pump evaporates in the combustion chamber, mixes with air from the combustion air fan and is ignited by the glow pin and flame sensor. The control module then progressively increases the speed of the auxiliary fuel pump and the combustion air fan. Once combustion is established the control module switches the glow pin and flame sensor from the glow pin function to the flame sensing function to monitor combustion. From the beginning of the start sequence to stable combustion at full load takes approximately 150 seconds.

Coolant Temperature Control: While the FFBH is running, the control module cycles the FFBH between full load

combustion, part load combustion and a control idle phase of operation, depending on the temperature of the coolant in the heat exchanger. The parked heating and auxiliary heating modes use different switching point temperatures from the supplementary heating mode, as detailed below.

Switching Point Diagram

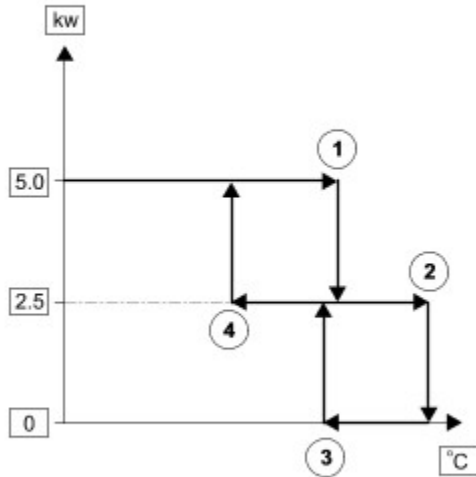

E51596

Switching Point Temperatures

Switching Point		Temperature, °C (°F)	
Figure Item No.	Description	Parked and Auxiliary Heating	Supplementary Heating
1	Full load to part load	76 (169)	72 (162)
2	Part load to control idle	82 (180)	78 (172)
3	Control idle to part load	74 (165)	70 (158)
4	Part load to full load	69 (156)	65 (149)

After the start sequence, the control module maintains full load combustion until the coolant temperature reaches switching point temperature 1. At this temperature, the control module decreases the speed of the auxiliary fuel pump and the combustion air fan to half speed, to produce part load combustion. The control module maintains part load combustion while the coolant temperature remains between switching point temperatures 2 and 4. At part load combustion the temperature of the coolant will increase or decrease depending on the amount of heat required to heat the vehicle interior. If the coolant temperature decreases to switching point temperature 4, the control module increases the speed of the auxiliary fuel pump and the combustion air fan to full speed, to return to full load combustion. If the coolant temperature increases to switching point temperature 2, the control module enters a control idle phase of operation.

On entering the control idle phase, the control module immediately switches the auxiliary fuel pump off, to stop combustion, and starts a timer for the combustion air fan. After a 2 minute cool down period, the control module switches the combustion air fan off and then remains in the control idle phase while the coolant temperature remains above switching point temperature 3. If the coolant temperature decreases to switching point temperature 3, the control module initiates a start to part load combustion. A start to part load combustion takes approximately 90 seconds.

In order to limit the build up of carbon deposits on the glow pin and flame sensor, the control module also enters the control idle phase if continuous combustion time exceeds 72 minutes (at part load, full load or a combination of both). After the cool down period, if the coolant is still in the temperature range that requires additional heat, the control module restarts the FFBH.

Shutdown: To stop the FFBH, the control module de-energizes the auxiliary fuel pump to stop combustion, but continues operation of the combustion air fan and the circulation pump for a time, to cool down the FFBH. The cool down time is 100 seconds if the FFBH was operating at part load combustion and 175 seconds if the FFBH was operating at full load combustion.

Supplementary Heating

Supplementary heating is requested by the ATCM while the engine is running if the ambient temperature is less than 5 °C (41 °F) and the engine coolant temperature is less than 75 °C (167 °F).

The ATCM cancels supplementary heating if the ambient temperature increases to 5 °C (41 °F), the engine coolant temperature increases to 75 °C (167 °F), or the engine stops.

Diagnostics

The control module monitors the FFBH system for faults. Any faults detected are stored in a volatile memory in the control module, which can be interrogated by T4. A maximum of three faults and associated freeze frame data can be stored at any one time. If a further fault is detected, the oldest fault is overwritten by the new fault.

The control module also incorporates an error lockout mode of operation that inhibits operation to prevent serious faults from causing further damage to the system. In the error lockout mode, the control module immediately stops the auxiliary fuel pump, and stops the combustion air fan and circulation pump after a cool down time of approximately 2 minutes. Error lockout occurs for start sequence failures, combustion flameouts, heat exchanger casing overheat and if battery voltage is out of limits. The error lockout mode can be cleared using T4, or by disconnecting the battery power supply (connector C0926) for a minimum of 10 seconds.

Start Failure and Flameout: If a start sequence fails to establish combustion, or a flameout occurs after combustion is established, the control module immediately initiates another start sequence. The start failure or flameout is also recorded by an event timer in the control module. The event timer is increased by one after each start failure or flameout, and decreased by one if a subsequent start is successful. If the event timer increases to three (over any number of drive cycles), the control module enters the error lockout mode.

Heat Exchanger Casing Overheat: To protect the system from excessive temperatures, the control module enters the error lockout mode if the heat exchanger coolant temperature exceeds 125 °C (257 °F).

Battery Voltage Limits: 10.25 - 15.5 volts.

AUXILIARY HEATING CONTROL DIAGRAM

NOTE :

A = Hardwired connections; D = High speed CAN bus; F = RF transmission; N = Medium speed CAN bus; P = MOST bus

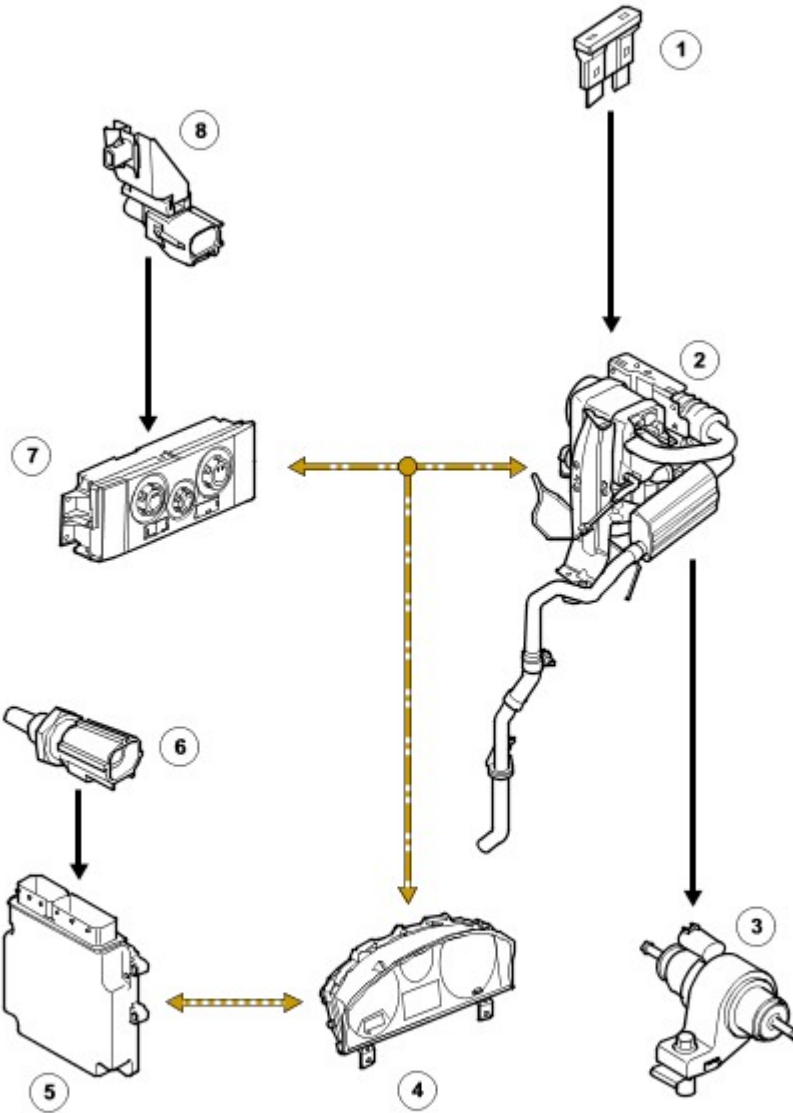

E43575



Item	Part Number	Description
1	-	Fuse 28E, Battery Junction Box (BJB)
2	-	FFBH
3	-	Auxiliary fuel pump
4	-	Instrument cluster
5	-	ECM
6	-	ECT sensor
7	-	ATCM
8	-	Ambient temperature sensor